

Whitepaper: The Most Advanced Fired Heater Convection Section Cleaning Robot

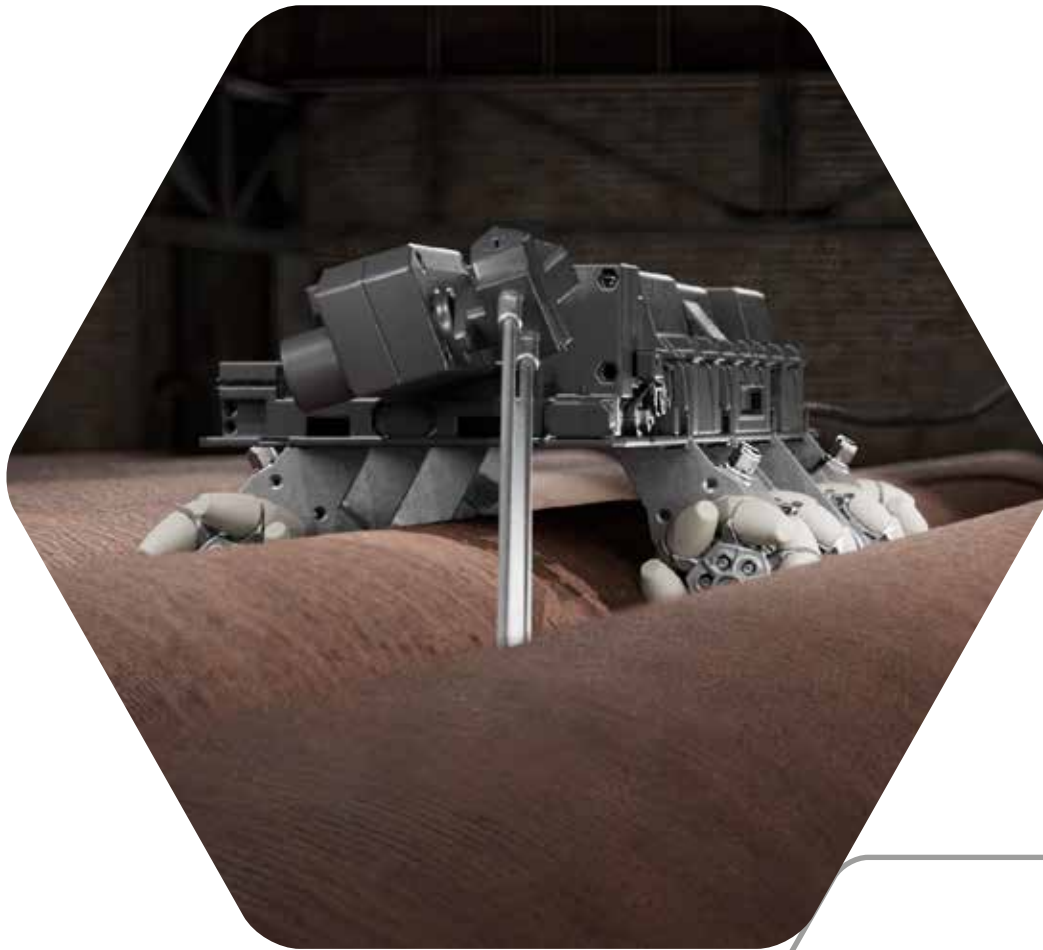



The Most Advanced Fired Heater Convection Section Cleaning Robot

The next generation IGS Tube Tech Mark 7 fired heater cleaning robot is capable of **autonomously eradicating more than 90% of convection section fouling**. The Mark 7 robot restores fired heater convection sections back to original design thermal efficiency regardless of the level or type of fouling, debottlenecking the heater and dramatically reducing fuel consumption, CO₂ and NO_x emissions.

More Efficient Cleaning

The new robotic technology, developed as a result of an extensive research and development programme, can automatically crawl over support plates, along and across finned or studded tubes, requiring fewer access points and enhancing its ability to access hard-to-reach areas. This defining feature makes cleaning faster and enables the robot to clean more in less time.

Blockage and Obstruction Detection

The automated rover uses lidar technology for distance sensing and can detect blockages or obstructions. Live HD footage provides the operator with real-time feedback from within the convection bank providing an accurate representation of its condition and any areas of concern. Images and videos can also be used for reporting and analysis.

R&D Manager Comment

"We have been developing the Mark 7 rover to be the safest, most effective, and intelligent system on the market capable of restoring convection section efficiency to design standards. Becoming part of the IGS portfolio of solutions has provided us with access to broader spectrum of advance technologies and expertise which has made the development of this system possible."



Key Features and Benefits

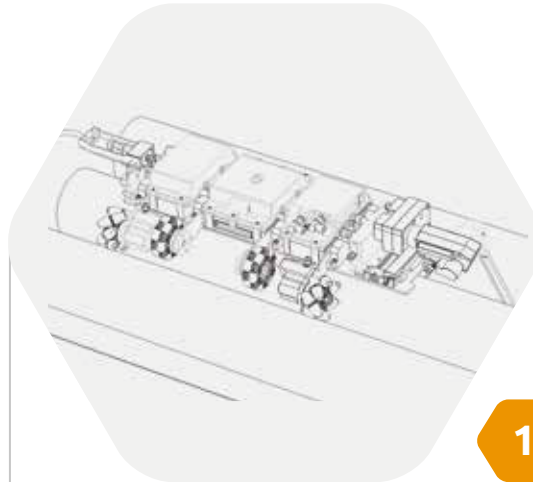

1

Ability to move across tubes

The rover can now **move across tubes and back to the open area** without the need for technician intervention, this allows for easier cleaning in hard-to-reach areas.

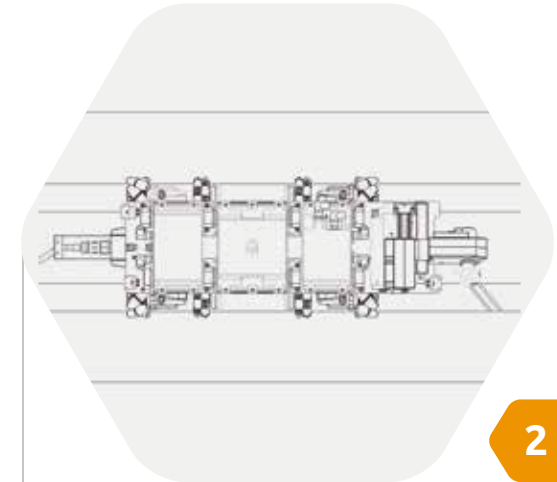

2

Self-aligned movement along the tubes

The new system has no need for guides and uses the tubes themselves to guide it along the bank – **removing any challenges with warped or uneven tubes.**

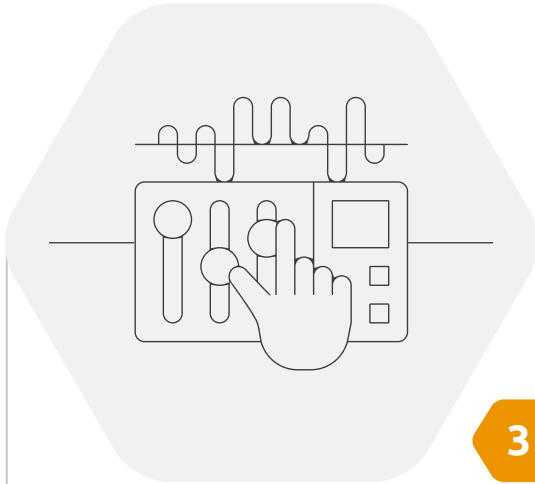

3

Universally usable – no set up required

Unlike previous rovers where tube pitch was set manually, **the MK7 can adjust itself** to the centre of the tube.



4

Automatically records and takes images

The system **records as it goes** helping to capture the information required for the report allowing the technicians to continue with the job at hand.



5

Automated cleaning and move functionality

The new system drives up and down the coiled tubes as well as traversing across them meaning that it can clean a **complete convection section autonomously** all from a **one-button start command**.

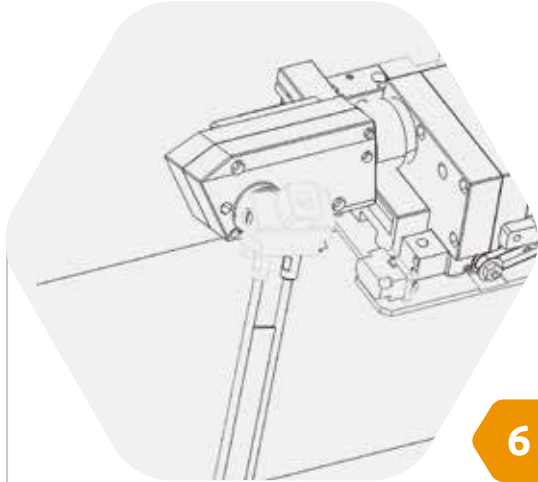

6

Flush and lance available on the same system

Modular based cleaning heads mean **the same ROV** can be used in all operations.

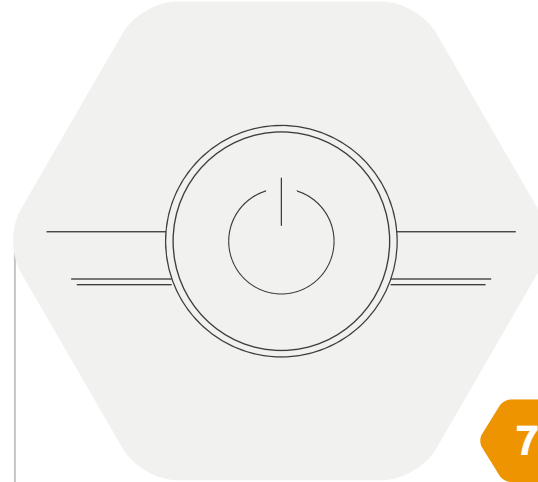

7

Power off and re-start functionality

If the unit stops for any reason, **memory feature** reverts back to last position.

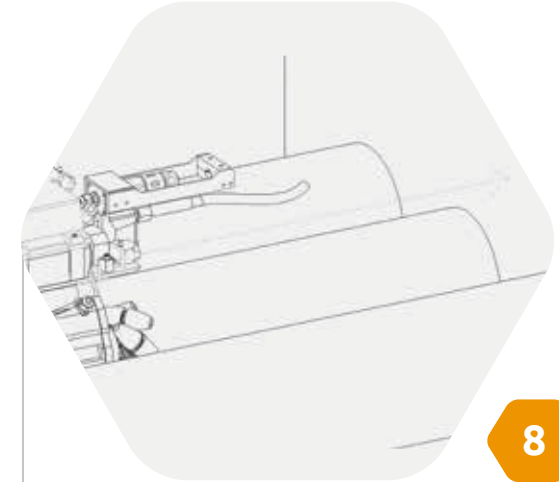

8

Lidar-controlled distance sensing

Moving along the bank is controlled by two lidar measurement devices, plus distance the wheels have moved, **creating a greater accuracy for positioning.**

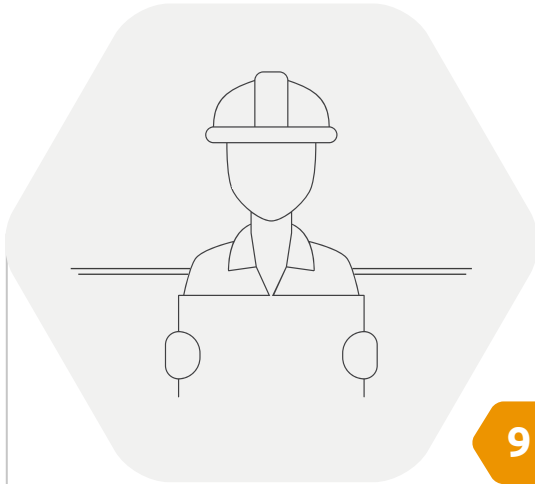

9

Supervisor override available

The system can **still be set manually**, by a supervisor, should working environment or heater dimensions require adjustment, allowing greater flexibility.

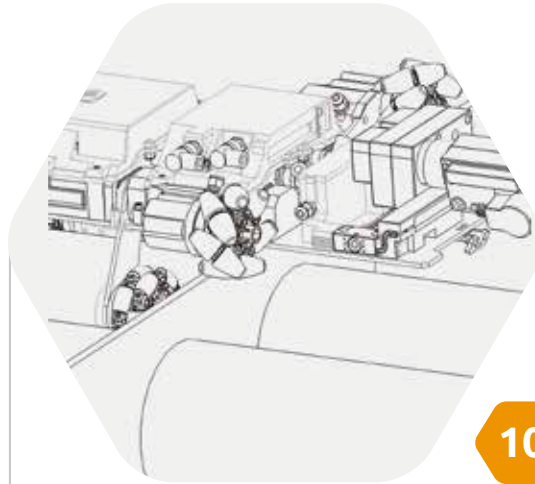

10

Support plate climbing function

This allows the system to climb over low intermediate support plates located on the coils/bundles. **Technicians can therefore work from fewer access points** along the furnace wall and the rover can travel further along the furnace.

Learn More about the IGS Tube Tech Mark 7 fired heater cleaning robot





Refining

Technology designed for continuous improvements in refinery heat transfer efficiency.

Unplanned or extended unit shutdowns can be very costly for refinery operators. Over the past three decades, Tube Tech has helped to minimise downtime and solve some of the most difficult fouling removal problems at oil and gas facilities around the world.

Tube Tech's rover technology has a proven track record of restoring convection section efficiency where traditional methods have tried and failed.

Ethylene Manufacturing

Technology designed for continuous improvements in refinery heattransfer efficiency.

Fired Heaters, including Ethylene Furnaces, have the greatest running cost on your site. If any one of these heaters is 1 or 2% inefficient it can consume an additional \$1m in fuel over a year or result in \$millions in lost revenue.

Tube Tech's ethylene furnace convection section cleaning service is recognised by world-leading refining and petrochemical companies as the most effective technology to achieve OEM performance clean fired heaters. the most difficult fouling removal problems at oil and gas facilities around the world.

Tube Tech's rover technology has a proven track record of restoring convection section efficiency where traditional methods have tried and failed.



90%+

Clean guarantee even on the most fouled assets.

Ammonia/Methanol/ Hydrogen Manufacturing (SMR)

Restoring efficiency and reducing emissions.

Steam Methane Reformer fouling is a costly problem for refineries around the world. Heater intake collects 1 ppm airborne particulate whilst in service, which results in deposits of 2.5 tonnes over 12 months either landing in or travelling through the heater.

Traditional cleaning methods are only able to clean 30-45% of the total fouled area. Tube Tech's Mark 7 rover system penetrates deep between tube rows to remove even the most stubborn fouling.



Chemical Industry

Raising performance, reliability, and profits for the chemical industry.

Improving fired heater performance is crucial for optimizing energy consumption, reducing emissions, and enhancing overall process performance. In large-scale chemical facilities, energy typically accounts for at least 50% of operating costs. An energy use reduction of 10% will often improve margins by 5% and reduce CO₂ emissions by 10%.

Tube Tech's Mark 7 rover system helps reduce energy consumption by removing fouling and restoring heat transfer efficiency.





integratedglobal.com

